



# Parts and Material Analysis Report

Customer	Braun Electronic Components LLC	Part Number	MK12DX256VLK5
Customer PO	000920-A	Manufacturer	NXP
Customer Address	1500 W Main St Suite 200, Sun Prairie, WI 53590 USA	Date/Lot Code	1750
Report Date	2/21/2023 4:56:42 PM	Quantity Revd	total: 1440 test: 3640
Revision	0	AAA WO #	W2302130002

## Summary

Result: C: Conforming, NC: Non Conforming, S: Suspect, NA: Not Applicable

Test-Process Operation	Test Quantity	Result	Comments
<b>General EVI &amp; Handling per AS6081, Section 4.2.6.4.1</b>			
Contract Review Items	1	C	
Box/Content Condition	1	C	
<b>Detailed Visual Inspection per AS6081, Section 4.2.6.4.2</b>			
Package Condition	125	C	Acceptable
Lead Condition	125	C	Acceptable
Part Markings	125	C	Acceptable
<b>Inspection for Remarking/Resurfacing per AS6081, Section 4.2.6.4.3</b>			
3:1 Marking Permanency	3	C	
Acetone Swab Test	3	C	
HCT-1 (1-Methyl, 2-Pyrrolidinone)	3	C	
HCT-2	3	C	
<b>XRF Evaluation per AS6081, Section 4.2.6.4.5</b>			
Lead Finish	3	C	Primarily Sn/Cu
<b>Internal Visual Inspection per AS6081, Section 4.2.6.4.6</b>			
Observed Defects	3	C	
<b>Radiological Inspection per AS6081, Section 4.2.6.4.4</b>			
Internal Construction	45	C	
<b>Electrical Testing per AAA 622-001 Section 13</b>			
Memory Test	116	116 pcs.	100% Pass
<b>Baking (JEDEC J-STD-033)</b>			
Bake/Dry Pack	122	C	

## Assessment

**Parts passed electrical testing.**



## Analysis Summary

### External Visual Inspection

External Visual Inspection on 125 samples marked with D/C: 1750 revealed legible device markings consistent with the lot traveler and published data related to the part. No secondary coating, sanding marks, cracks, or chips were observed on all devices inspected. Leads were in acceptable condition.

Part markings were consistent throughout the samples inspected and matched manufacturer's ordering information.

Device package characteristics and dimensions matched manufacturer's specification.

No records of suspect counterfeit parts were found for this part number in the ERAI/GIDEP data bases.

NOTE: All inspections in this section performed in accordance with AAA Test Procedure Manual, 622-001, Sections 1-3; microscope magnification = 10X to 30X unless otherwise noted.

### Internal Visual Inspection

Internal Visual Inspection on 3 sample(s) marked with D/C: 1750 revealed Manufacturer FREESCALE marking and die marking N62JK20\_512. Device confirmed to be a NXP die.

Die markings consistent with information in the AAA die bank data base for this part number.

No information in the AAA die bank data base for this part number.

Testing performed in accordance with AAA Test Procedure Manual, 622-001, Section 4

"NXP and Freescale Announce \$40 Billion Merger - March 2, 2015" <https://www.nxp.com/company/about-nxp/nxp-and-freescale-announce-40-billion-merger:NW-FREESCALE-40BILLION-MERGE>

### Electrical Test

Parts tested: 116

Parts Passed: 116

Test notes: 116 devices passed all tested parameters.

### X-Ray Inspection

Radioscopic (X-ray) analysis of 45 random sample(s) revealed the same internal structure on all the samples. No internal damages were observed during inspection.

Radioscopic inspection performed in accordance with AAA Test Procedure Manual, 622-001, Section 7

Represented images are typical. All images are available on request.

Equipment: Creative Electron Tru-View Prime X-Ray, Calibration due 10/28/23)

### XRF Analysis

XRF Analysis performed on 3 random samples revealed the elemental composition of the devices, as shown in the table below.

Reading	Fe %	Ni %	Cu %	Ag %	W %	Au %	Al %	Sn %	Pb %



1	0.46	0.00	45.11	1.32	5.35	1.09	0.00	46.61	0.07
2	0.35	0.00	38.07	1.12	3.64	1.50	0.00	55.27	0.04
3	0.48	0.00	49.00	1.22	4.56	1.57	0.00	43.08	0.10

Statistics	Fe %	Ni %	Cu %	Ag %	W %	Au %	Al %	Sn %	Pb %
Mean	0.4	0.0	44.1	1.2	4.5	1.4	0.0	48.3	0.1
Minimum	0.4	0.0	38.1	1.1	3.6	1.1	0.0	43.1	0.0
Maximum	0.5	0.0	49.0	1.3	5.3	1.6	0.0	55.3	0.1
Std Dev	0.1	0.0	5.5	0.1	0.9	0.3	0.0	6.3	0.0

XRF spectrometer analyzers do not conclusively measure the elemental composition of any samples but do measure the % of each element relative to the others being measured. No comparison to actual manufacturer composition declarations should be made or implied.

XRF testing performed in accordance with AAA Test Procedure Manual, 622-001, Section 8

### Baking

Parts baked for 27 hours

### Solvent Test

Marking Permanency Test results were negative - no markings were removed.

Acetone Test results for resurfacing were negative - no residue was deposited on the swab.

HCT-1 Test results for resurfacing were positive - residue was deposited on the swab, no sanding marks or previous markings were exposed.

HCT-2 Test results for resurfacing were positive - residue was deposited on the swab, no sanding marks or previous markings were exposed.

Note: HCT-1: 1-Methyl 2-Pyrrolidinone; HCT-2: Dynasolve 715

Testing performed in accordance with AAA Test Procedure Manual, 622-001, Section 5



## Device Description

Device	<p><b>ARM® Cortex®-M4 Kinetis K10 Microcontroller IC 32-Bit Single-Core 50MHz 256KB (256K x 8) FLASH 80-FQFP (12x12)</b></p> <p>Speed 50MHz  Connectivity I<sup>2</sup>C, IrDA, SPI, UART/USART  Peripherals DMA, I<sup>2</sup>S, LVD, POR, PWM, WDT  Number of I/O 60  Program Memory Size 256KB (256K x 8)  Program Memory Type FLASH  EEPROM Size 4K x 8  RAM Size 32K x 8  Voltage - Supply (Vcc/Vdd) 1.71V ~ 3.6V  Data Converters A/D 24x16b; D/A 1x12b  Oscillator Type Internal  Operating Temperature -40°C ~ 105°C (TA)  Package / Case 80-LQFP  RoHS Status ROHS3 Compliant  Moisture Sensitivity Level (MSL) 3 (168 Hours)  REACH Status REACH Unaffected  ECCN 3A991A2  HTSUS 8542.31.0001</p>
Case	<b>80-Pin FQFP</b>
PDF	<a href="https://www.nxp.com/docs/en/data-sheet/K12P80M50SF4.pdf">https://www.nxp.com/docs/en/data-sheet/K12P80M50SF4.pdf</a>
Datasheet	<b>Rev. 4.1, 08/2013</b>

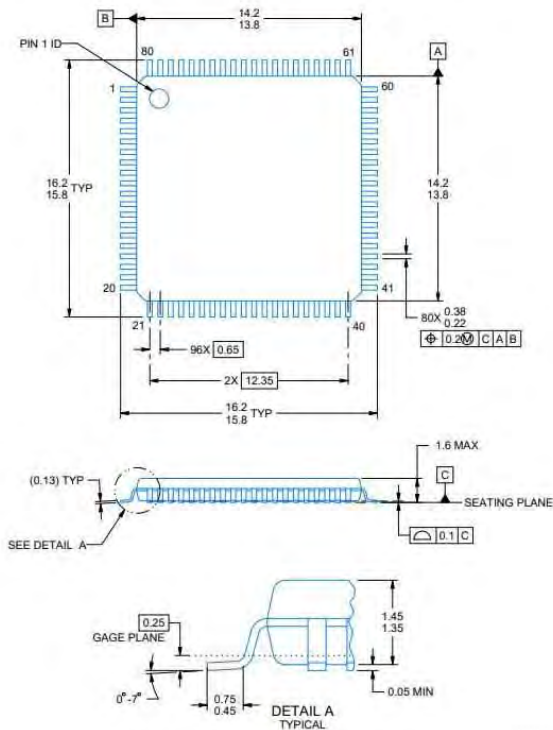



## Receiving - Documentation and Package Inspection

### General EVI & Handling per AS6081, Section 4.2.6.4.1

Result: C: Conforming, NC: Non Conforming, S: Suspect, NA: Not Applicable

<b>Date:</b>	2/13/2023 3:15:06 PM	<b>Tech:</b>	amber
<b>Device Count:</b>	1440	<b>Date/Lot Code:</b>	1750
<b>Weight:</b>	27.0000 lbs	<b>ESD Protection:</b>	Present
<b>Moisture Protection:</b>	Present WITH Indicator and Desiccant	<b>Carrier Type:</b>	Tray

Criteria	Result	Comments
<b>Receiving - Documentation and Package Inspection</b>		
Lot/Date Code information consistent with published data	C	1 Date Code 1750, 3 Separate Lots.
Manufacturer label/logo are present and matches datasheet and prev orders	NA	
Documentation review	C	
Barcode data scans and matches	NA	
Consistent package materials	NA	
<b>General Visual Inspection</b>		
Parts received in a single shipment	C	
Consistent part markings throughout lot	C	
Consistent appearance	C	
Consistent handling, packaging and storage	NA	
No evidence parts have been separated	NA	
Box received in acceptable condition. Devices were received in acceptable condition. Part markings were consistent throughout samples inspected and did match customer order information.		



**Incoming Box**



**Package Condition**



### Receiving Inspection ( Continued )



ESD Protection



Bag 1 Label Sample



Bag 2 Label Sample



Package Type

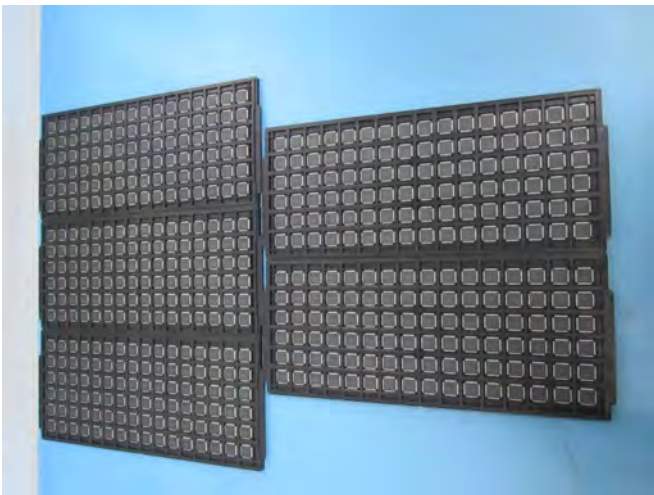

5 Trays Containing 480 Devices Received Sample

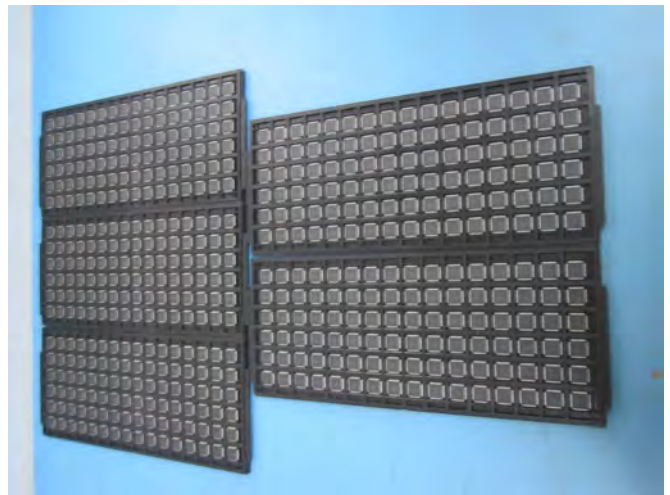

5 Trays Containing 480 Devices Received Sample



## Detailed External Visual Inspection

### Detailed Visual Inspection per AS6081, Section 4.2.6.4.2.2

Result: C: Conforming, NC: Non Conforming, S: Suspect, NA: Not Applicable

Criteria	Sample Size	Result	Comments
<b>General Conditions</b>			
Pin/Lead Count	125	C	80
Package Type	125	C	QFP
Verify Pin 1 placement	125	C	Acceptable
Part Markings	125	C	Acceptable
Package Conditions	125	C	Acceptable
Mold Cavities	125	C	Acceptable
Plating	125	C	Acceptable
Lead/Ball Conditions	125	C	Acceptable
Dimensions	125	C	Acceptable
GIDEP Verification	125	C	No Records
ERAI Verification	125	C	No Records
<b>Discrepant Markings</b>			
Different Marking styles	125	C	Same
Different Country of Origin	125	C	Taiwan
Different Body Molds	125	C	Acceptable
Different backside Markings	125	C	None
Previous marking partially visible	125	C	None
<b>Device Package Irregularities:</b>			
Uneven thickness	125	C	None
Dimples with uneven depth	125	C	None
Visible Scratch Marks	125	C	None
Significant package variation	125	C	None
Difference in the corner radius	125	C	None
Visible Damage (Cracks, burn marks)	125	C	None
Color or texture discrepancy	125	C	None
Foreign substance on surface	125	C	None
Evidence of color fade on the body	125	C	None
Signs of corrosion	125	C	None



## Detailed External Visual Inspection ( Continued )

External Visual Inspection on 125 samples marked with D/C: 1750 revealed legible device markings consistent with the lot traveler and published data related to the part. No secondary coating, sanding marks, cracks, or chips were observed on all devices inspected. Leads were in acceptable condition.

Part markings were consistent throughout the samples inspected and matched manufacturer's ordering information.

Device package characteristics and dimensions matched manufacturer's specification.

No records of suspect counterfeit parts were found for this part number in the ERAI/GIDEP data bases.

**NOTE:** All inspections in this section performed in accordance with AAA Test Procedure Manual, 622-001, Sections 1-3; microscope magnification = 10X to 30X unless otherwise noted.

Test Operator:	R Legge
Test Date:	2/20/2023

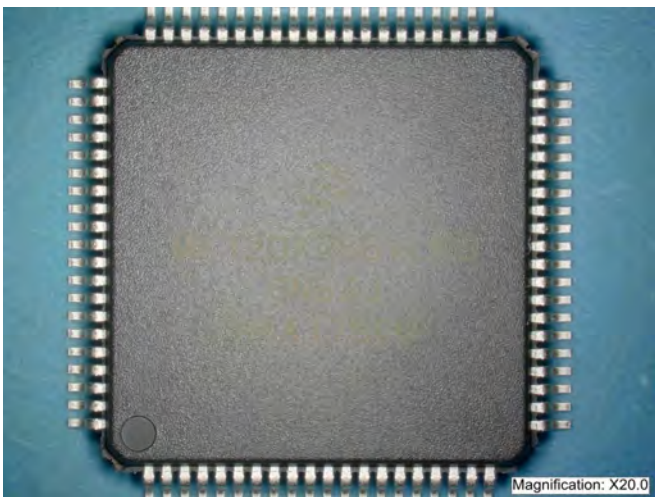

Top

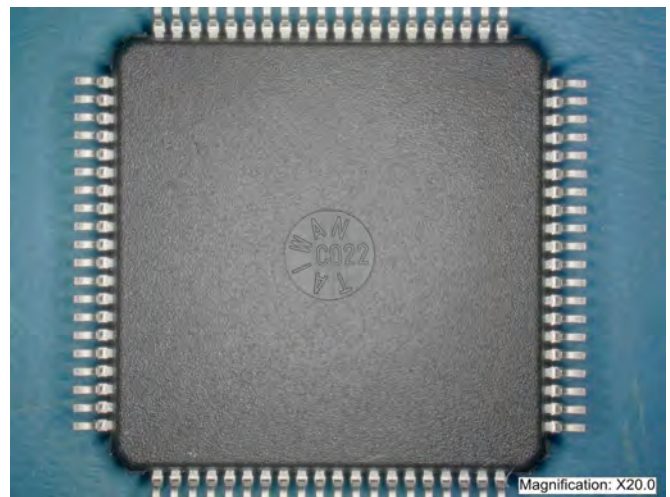

Bottom



Side

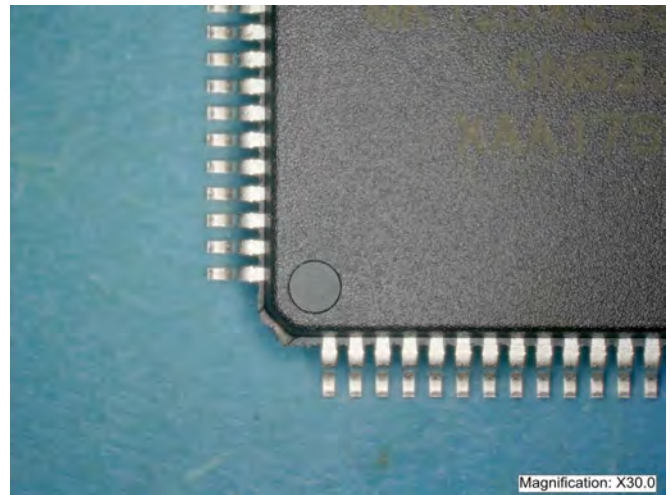

Top Pin





### Detailed External Visual Inspection ( Continued )



Bottom Pin



Leads View 1

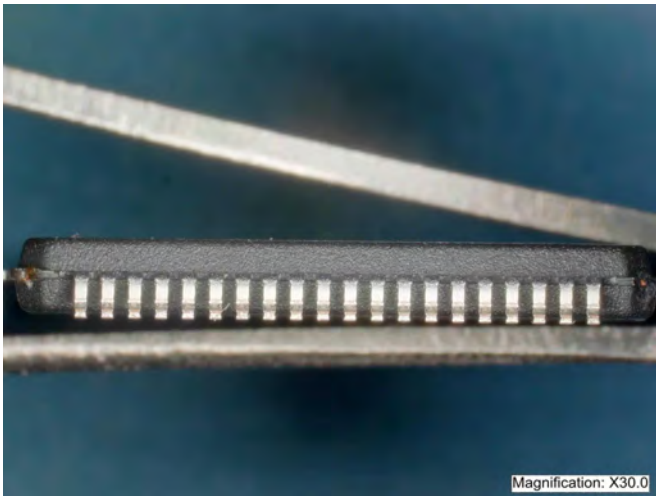

Leads View 2

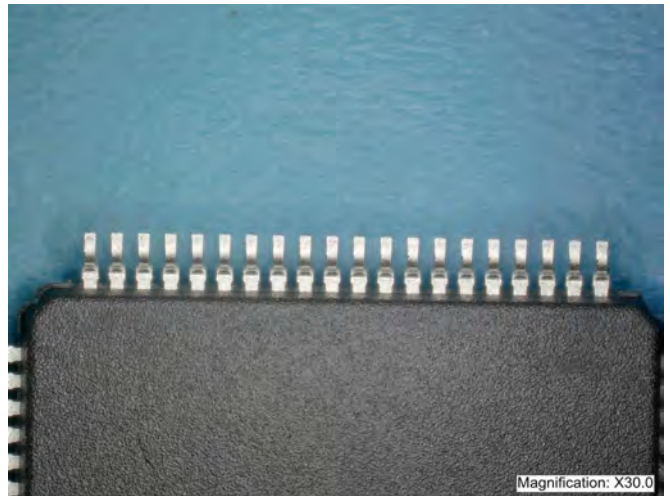

Leads View 3



Top Marking

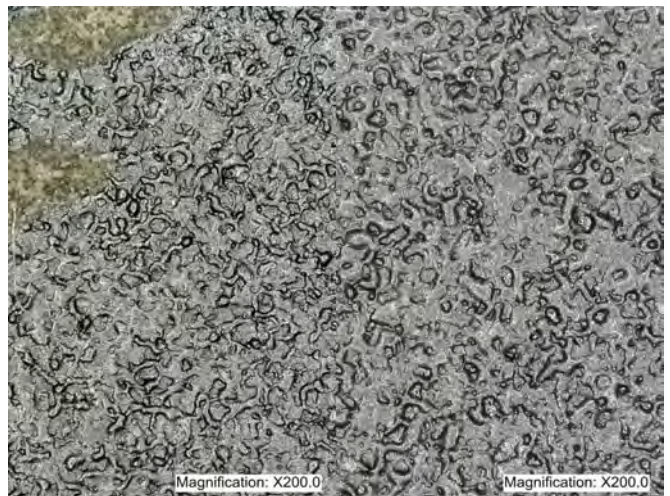

Top/Bottom Comparison



### Detailed External Visual Inspection ( Continued )



**Length**



**Width**



**Thickness**

Measurement	Type	Average	Minimum	Maximum
Length (mm)	Specification	14.00	—	—
	Measurement	14.05	14.00	14.07
Width (mm)	Specification	14.00	—	—
	Measurement	14.04	13.99	14.09
Thickness (mm)	Specification	—	—	1.60
	Measurement	1.49	1.46	1.50

**Dimensions Table**



## Solvent/Chemical Testing

### Inspection for Remarketing/Resurfacing per AS6081, Section 4.2.6.4.3

Result: C: Conforming, NC: Non Conforming, S: Suspect, NA: Not Applicable

Criteria	Sample Size	Result	Comments
Marking Permanency	3	C	
Acetone Swab Test	3	C	
HCT-1 (1-Methyl, 2-Pyrrolidione)	3	C	
HCT-2	3	C	
<p>Marking Permanency Test results were negative - no markings were removed.            Acetone Test results for resurfacing were negative - no residue was deposited on the swab.            HCT-1 Test results for resurfacing were positive - residue was deposited on the swab, no sanding marks or previous markings were exposed.            HCT-2 Test results for resurfacing were positive - residue was deposited on the swab, no sanding marks or previous markings were exposed.</p> <p>Note: HCT-1: 1-Methyl 2-Pyrrolidinone; HCT-2: Dynasolve 715</p> <p>Testing performed in accordance with AAA Test Procedure Manual, 622-001, Section 5</p>			
Test Operator	R King		
Test Date	2/21/2023		



After Permanency

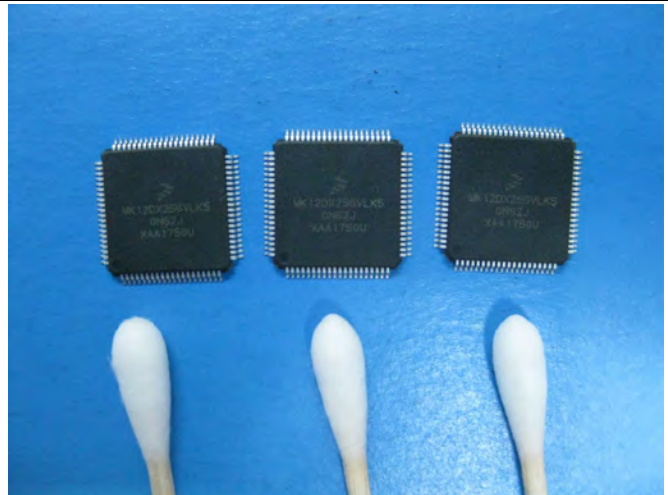

After Acetone



### Solvent/Chemical Testing (Continued)

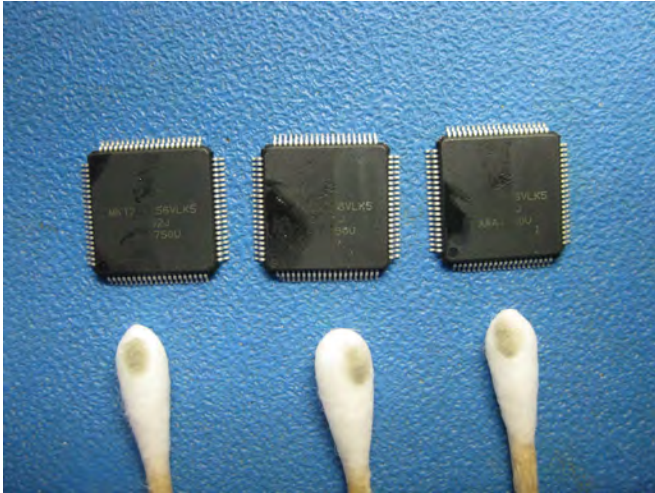

After HCT-1

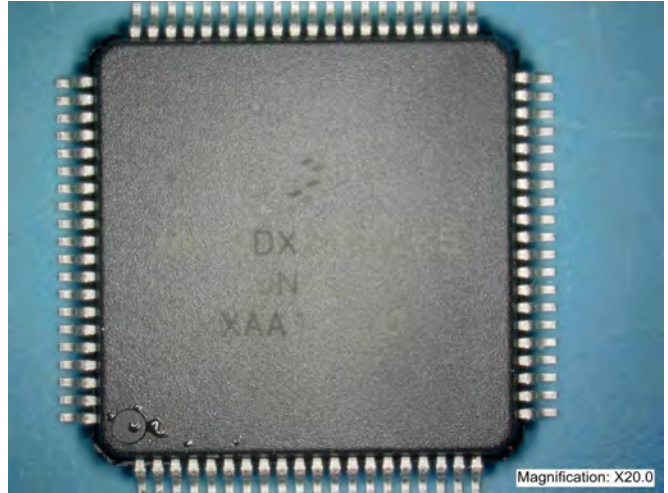

After HCT-1 Closeup - Device 1



After HCT-1 Closeup - Device 2



After HCT-1 Closeup - Device 3

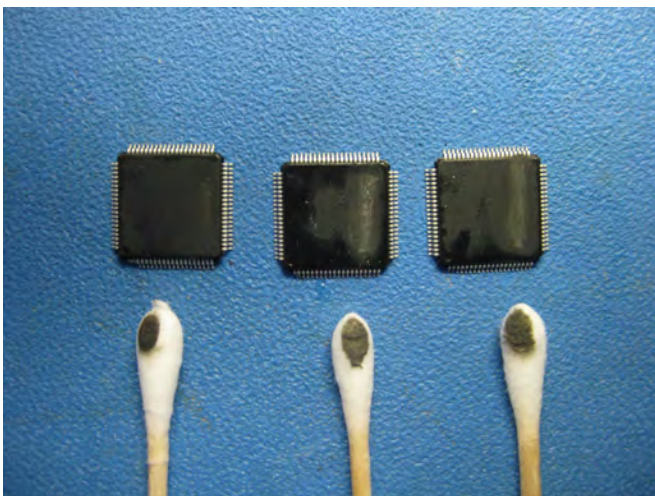

After HCT-2



After HCT-2 Closeup - Device 1



### Solvent/Chemical Testing ( Continued )



After HCT-2 Closeup - Device 2



After HCT-2 Closeup - Device 3



## XRF Analysis

### XRF Evaluation per AS6081, Section 4.2.6.4.5

Result: C: Conforming, NC: Non Conforming, S: Suspect, NA: Not Applicable

Criteria	Sample Size	Result	Comments						
<b>Consistent Lead Finish &amp; Material Composition</b>	3	C	Primarily Sn/Cu						
XRF Analysis performed on 3 random samples revealed the elemental composition of the devices, as shown in the table below.									
Reading	Fe %	Ni %	Cu %	Ag %	W %	Au %	Al %	Sn %	Pb %
1	0.46	0.00	45.11	1.32	5.35	1.09	0.00	46.61	0.07
2	0.35	0.00	38.07	1.12	3.64	1.50	0.00	55.27	0.04
3	0.48	0.00	49.00	1.22	4.56	1.57	0.00	43.08	0.10
Statistics	Fe %	Ni %	Cu %	Ag %	W %	Au %	Al %	Sn %	Pb %
Mean	0.4	0.0	44.1	1.2	4.5	1.4	0.0	48.3	0.1
Minimum	0.4	0.0	38.1	1.1	3.6	1.1	0.0	43.1	0.0
Maximum	0.5	0.0	49.0	1.3	5.3	1.6	0.0	55.3	0.1
Std Dev	0.1	0.0	5.5	0.1	0.9	0.3	0.0	6.3	0.0
XRF spectrometer analyzers do not conclusively measure the elemental composition of any samples but do measure the % of each element relative to the others being measured. No comparison to actual manufacturer composition declarations should be made or implied.									
XRF testing performed in accordance with AAA Test Procedure Manual, 622-001, Section 8									
<b>Test Operator</b>	J Burns								
<b>Test Date</b>	2/20/2023								



## XRF Analysis ( Continued )

**AAA Test Lab**  
2320 Commerce Park Dr NE, Palm  
Bay, FL 32905



**AAA Test Lab, Inc.**  
ISO/IEC 17025:2017 Accredited

Bowman P Series XRF

Read Time (s): 30  
Session Date: 2/20/2023 15:24  
Collimator: 4mil

Operator Initials: JWB  
Workorder: W2302130002  
Customer: Braun  
Part Number: MK12DX256VLK5

Reading	Fe %	Ni %	Cu %	Ag %	W %	Au %	Al %	Sn %	Pb %
1	0.46	0.00	45.11	1.32	5.35	1.09	0.00	46.61	0.07
2	0.35	0.00	38.07	1.12	3.64	1.50	0.00	55.27	0.04
3	0.48	0.00	49.00	1.22	4.56	1.57	0.00	43.08	0.10

Statistics	Fe %	Ni %	Cu %	Ag %	W %	Au %	Al %	Sn %	Pb %
Mean	0.4	0.0	44.1	1.2	4.5	1.4	0.0	48.3	0.1
Minimum	0.4	0.0	38.1	1.1	3.6	1.1	0.0	43.1	0.0
Maximum	0.5	0.0	49.0	1.3	5.3	1.6	0.0	55.3	0.1
Std Dev	0.1	0.0	5.5	0.1	0.9	0.3	0.0	6.3	0.0



Result 1



Result 2



Result 3

### XRF Results



### XRF Analysis ( Continued )

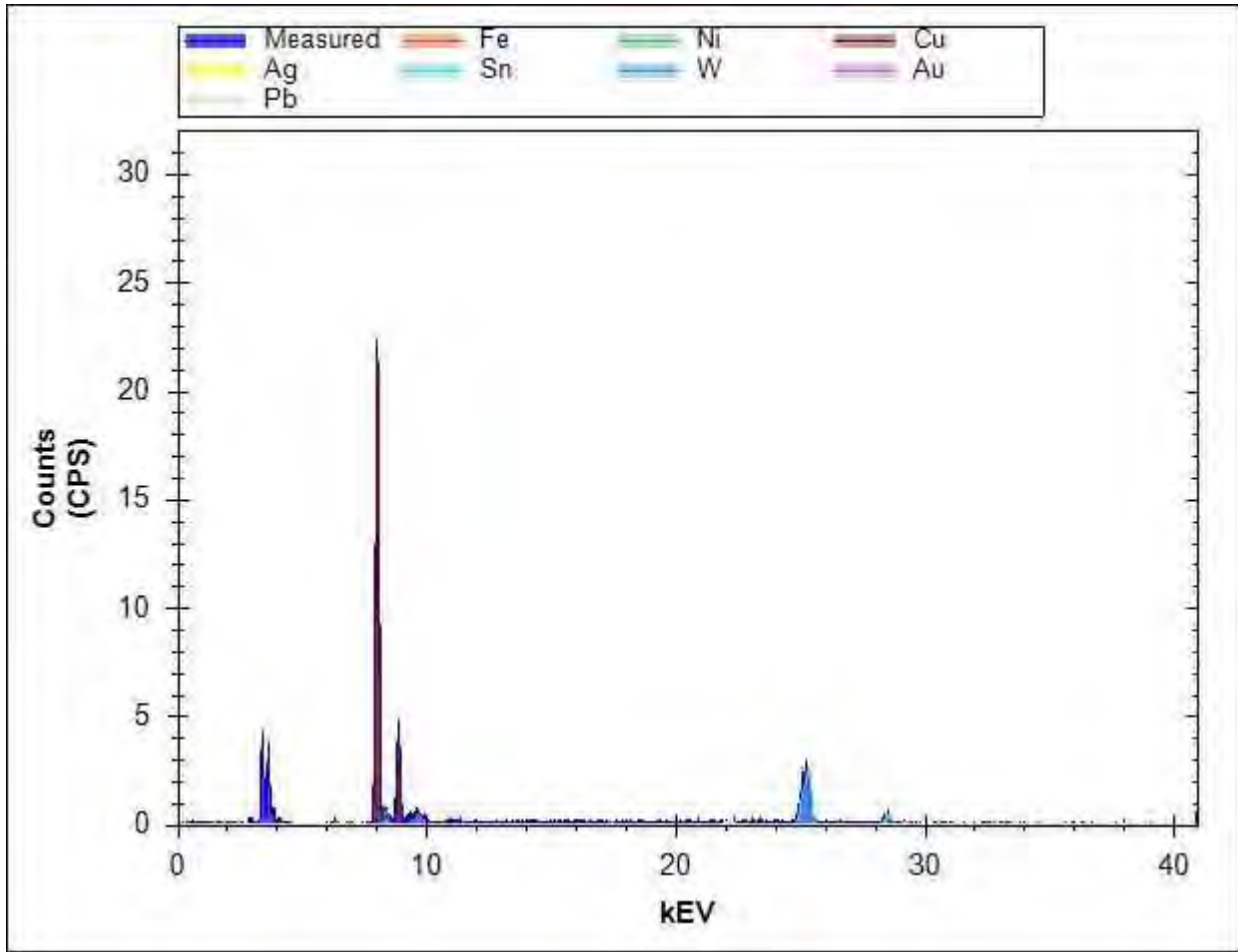

XRF Spectrum - Sample 1





### XRF Analysis ( Continued )

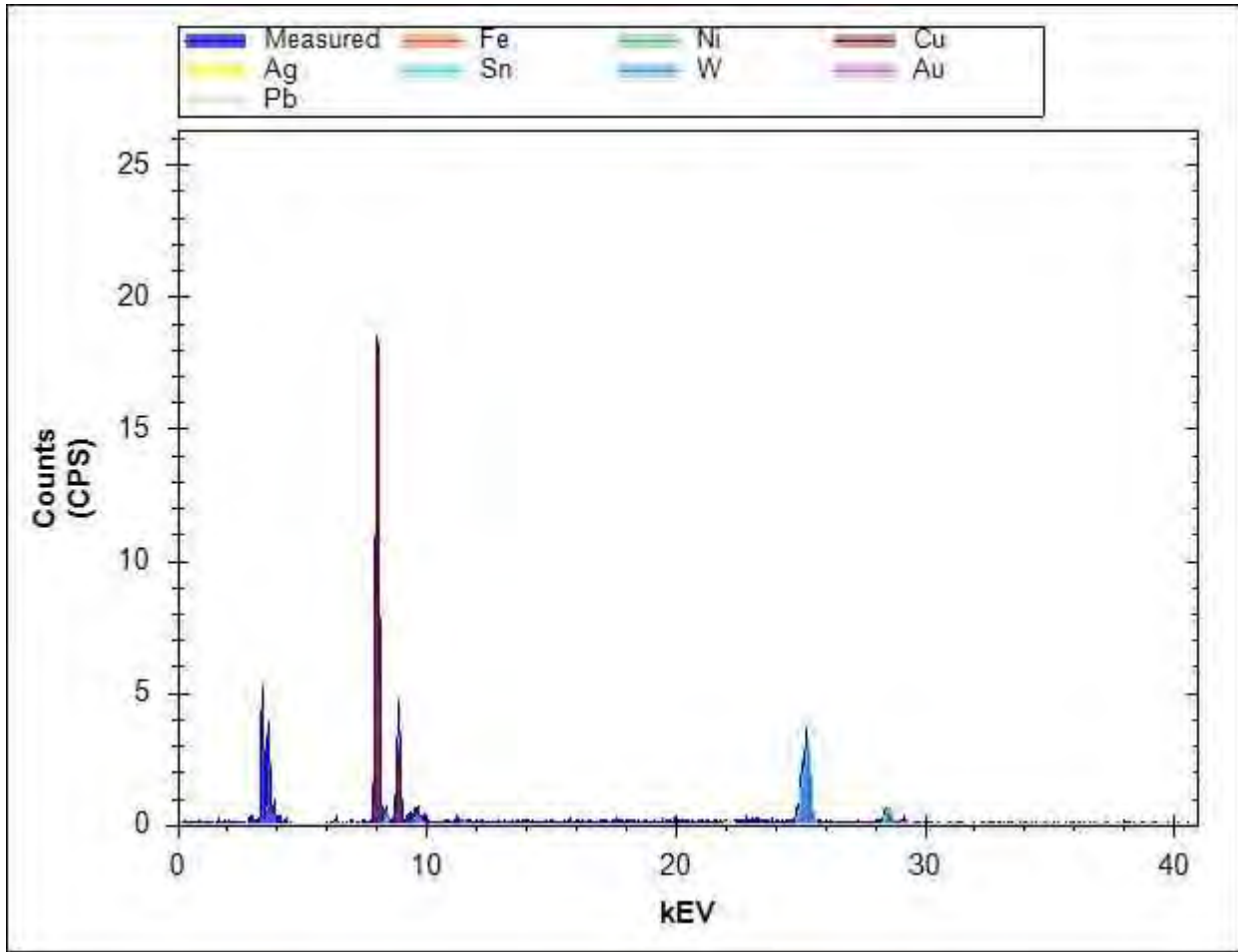

XRF Spectrum - Sample 2



### XRF Analysis ( Continued )

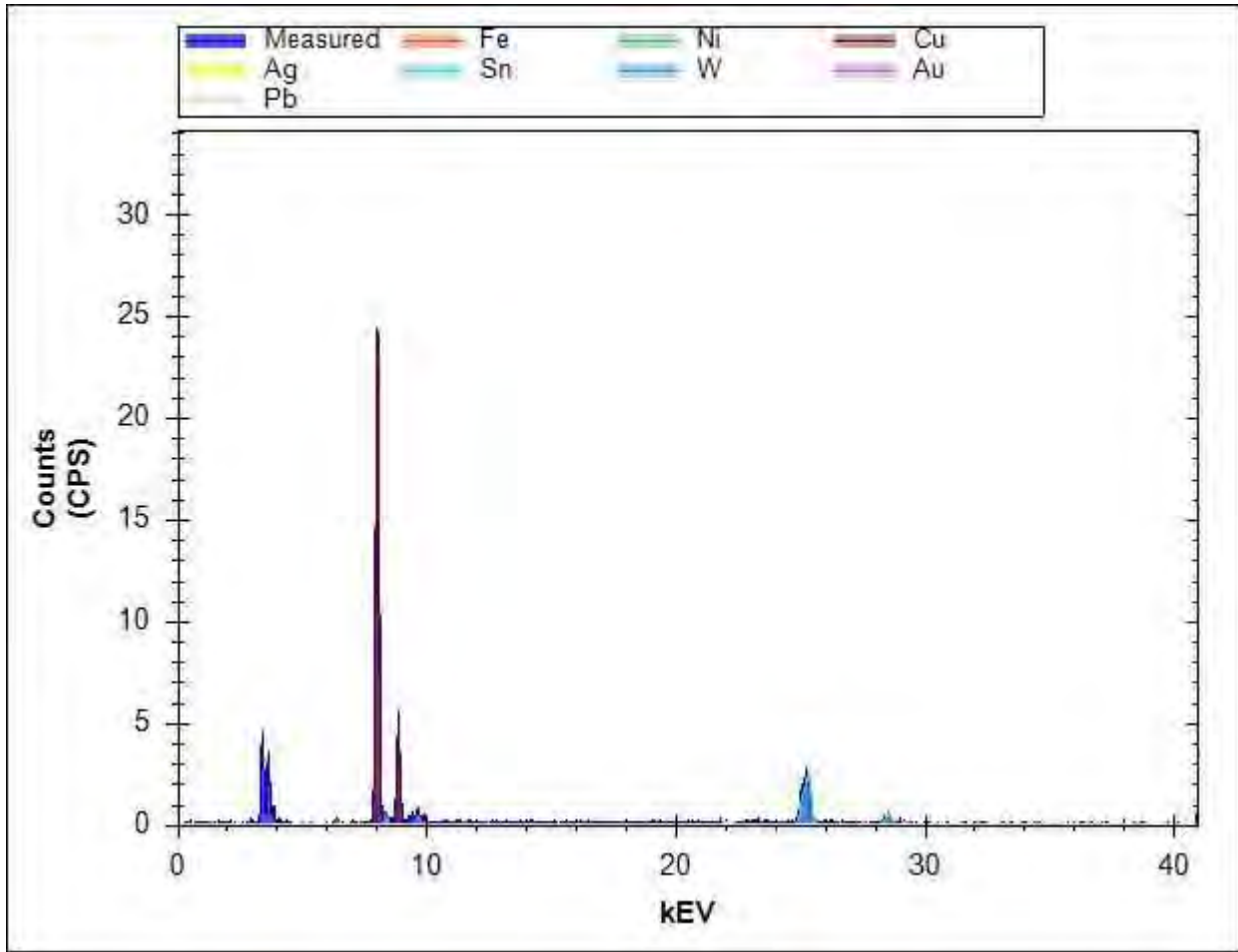

XRF Spectrum - Sample 3



## DDPA & Internal Visual Inspection

### Internal Visual Inspection per AS6081, Section 4.2.6.4.6

Result: C: Conforming, NC: Non Conforming, S: Suspect, NA: Not Applicable

Criteria	Sample Size	Result	Comments
Die Verification Match "Known Good" or AAA Data Base	3	NA	
Observed Defects	3	C	
Topography/Markings Match "Known Good" or AAA Data Base	3	C	
<p>Internal Visual Inspection on 3 sample(s) marked with D/C: 1750 revealed Manufacturer FREESCALE marking and die marking N62JK20_512. Device confirmed to be a NXP die.</p> <p>Die markings consistent with information in the AAA die bank data base for this part number. No information in the AAA die bank data base for this part number.</p> <p>Testing performed in accordance with AAA Test Procedure Manual, 622-001, Section 4</p> <p>"NXP and Freescale Announce \$40 Billion Merger - March 2, 2015" <a href="https://www.nxp.com/company/about-nxp/nxp-and-freescale-announce-40-billion-merger:NW-FREESCALE-40BILLION-MERGE">https://www.nxp.com/company/about-nxp/nxp-and-freescale-announce-40-billion-merger:NW-FREESCALE-40BILLION-MERGE</a></p>			
Test Operator	R King		
Test Date	2/21/2023		

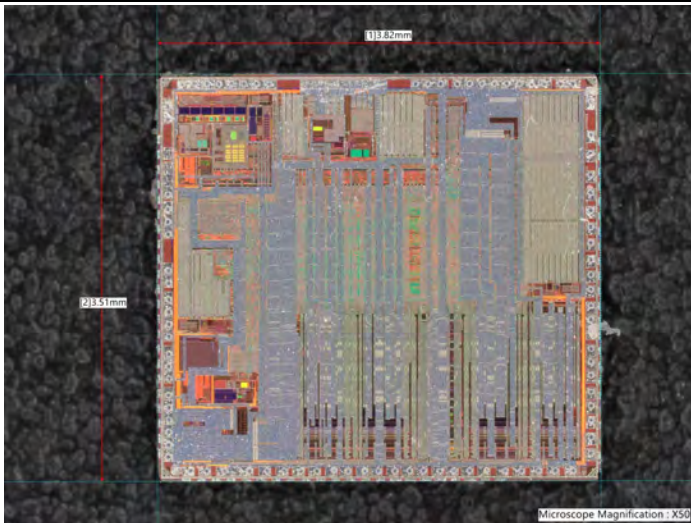

Die Topography - Device 1

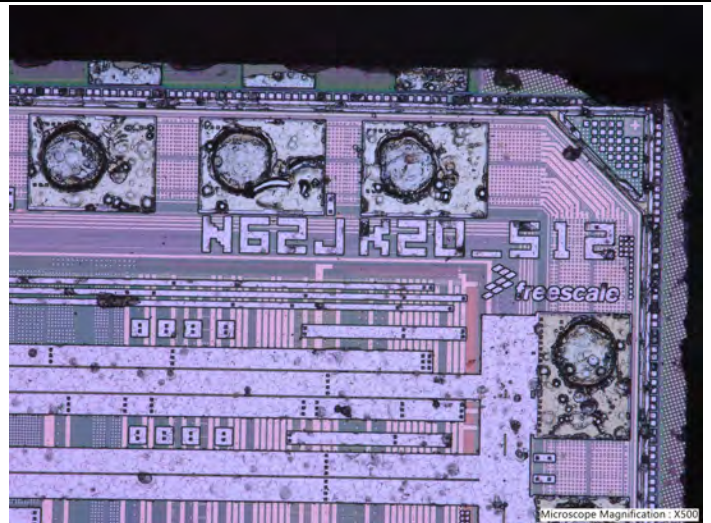

Die Markings - Device 1



## DDPA & Internal Visual Inspection ( Continued )

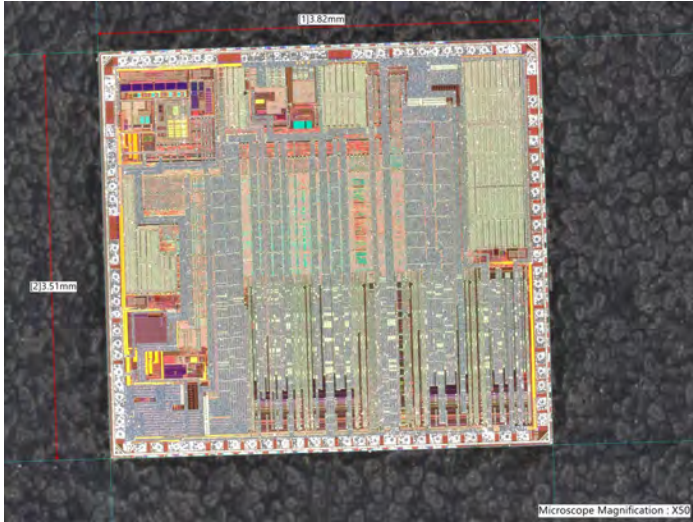

Die Topography - Device 2

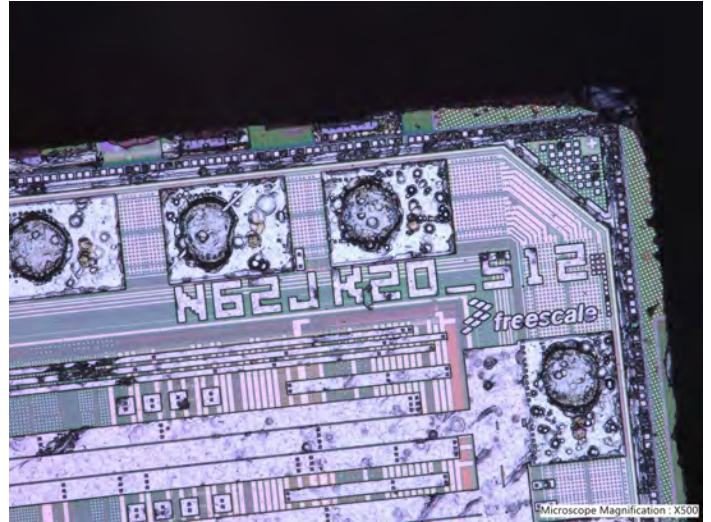

Die Markings - Device 2

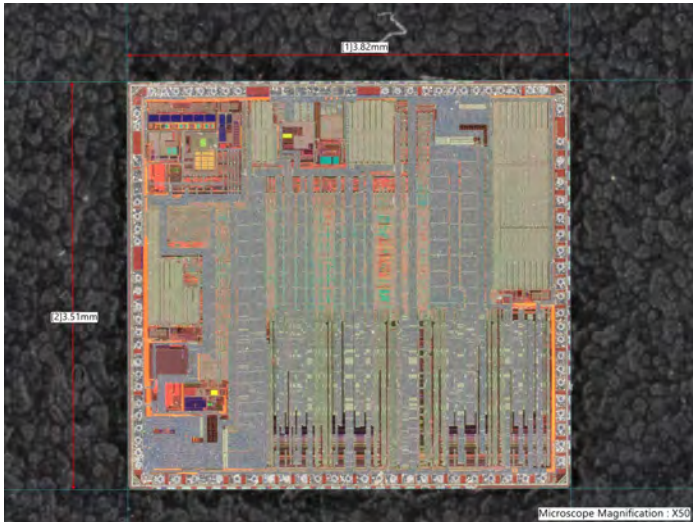

Die Topography - Device 3

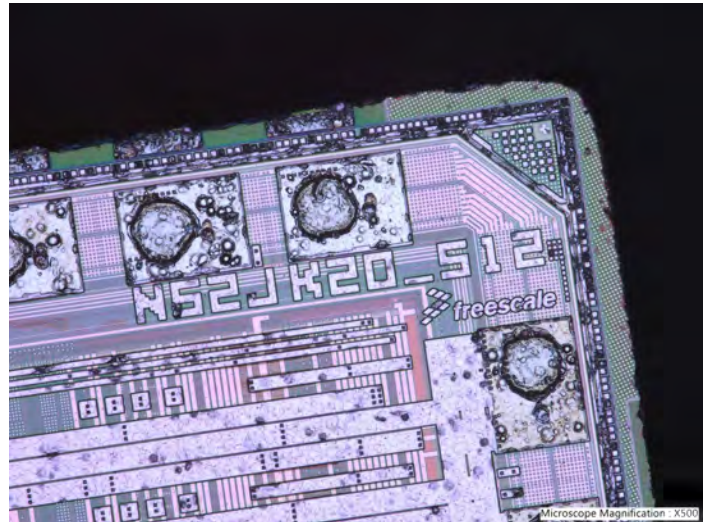

Die Markings - Device 3



## X-Ray Inspection

### Radiological Inspection per AS6081, Section 4.2.6.4.4

Result: C: Conforming, NC: Non Conforming, S: Suspect, NA: Not Applicable

Criteria	Sample Size	Result	Comments
Consistent Internal Contents	45	C	
Tube Voltage	90 kV		
Dosage Time	240 Seconds		
<p>Radioscopic (X-ray) analysis of 45 random sample(s) revealed the same internal structure on all the samples. No internal damages were observed during inspection.</p> <p>Radioscopic inspection performed in accordance with AAA Test Procedure Manual, 622-001, Section 7</p> <p>Represented images are typical. All images are available on request.</p> <p>Equipment: Creative Electron Tru-View Prime X-Ray, Calibration due 10/28/23)</p>			
Test Operator	J Vue		
Test Date	2/21/2023		

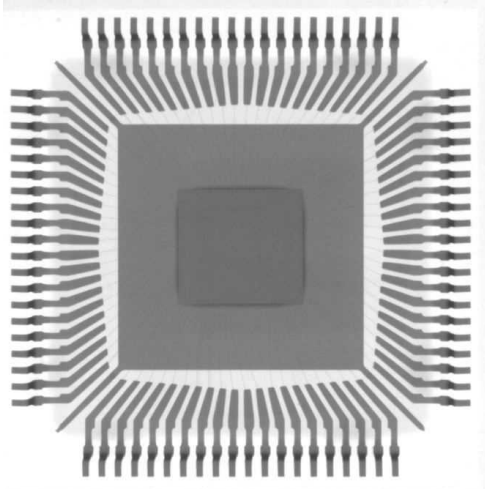

**X-Ray Analysis - Sample 1**

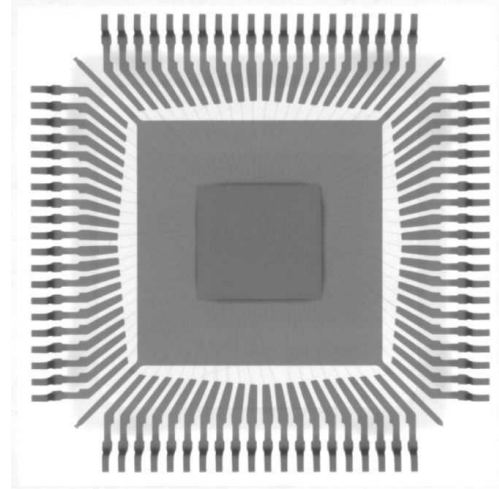

**X-Ray Analysis - Sample 2**



## X-Ray Inspection ( Continued )

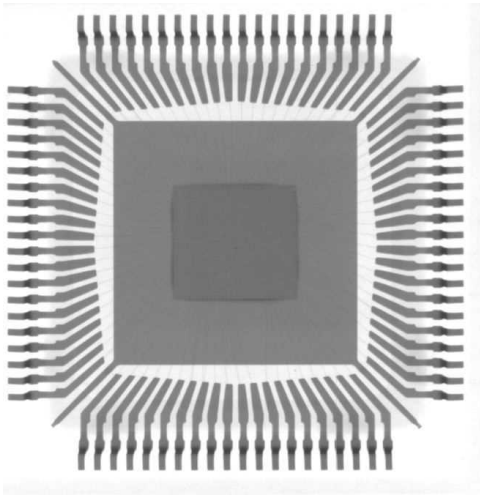

X-Ray Analysis - Sample 3

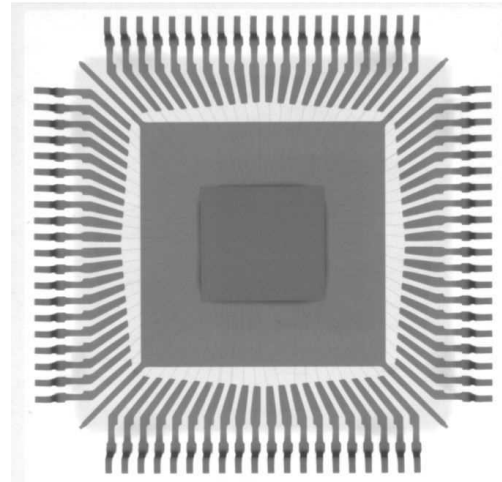

X-Ray Analysis - Sample 4

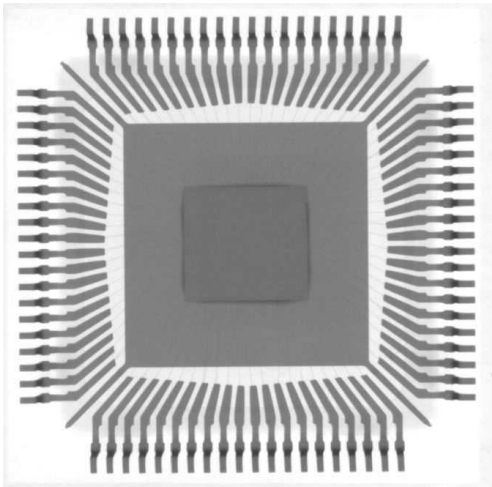

X-Ray Analysis - Sample 5

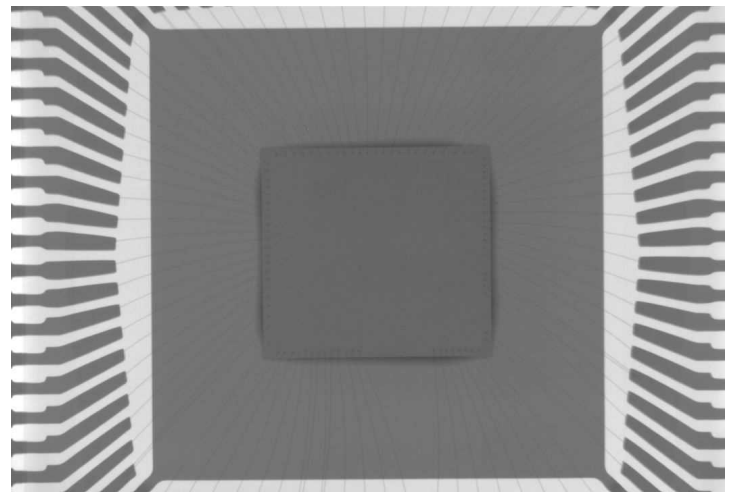

X-Ray Analysis - Die Shot Sample 1

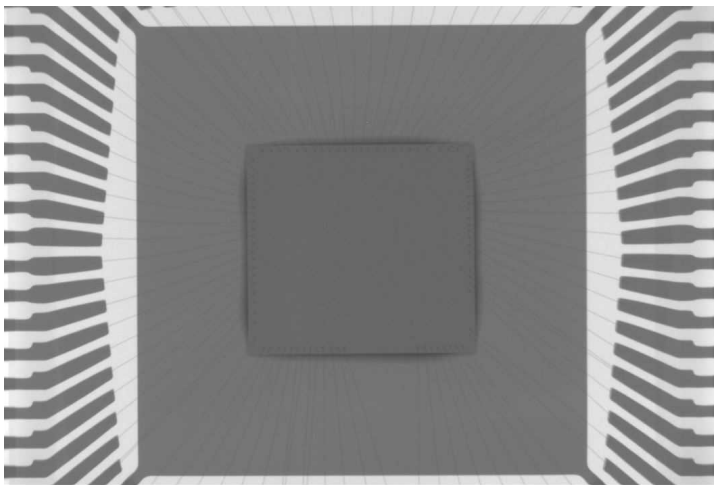

X-Ray Analysis - Die Shot Sample 2

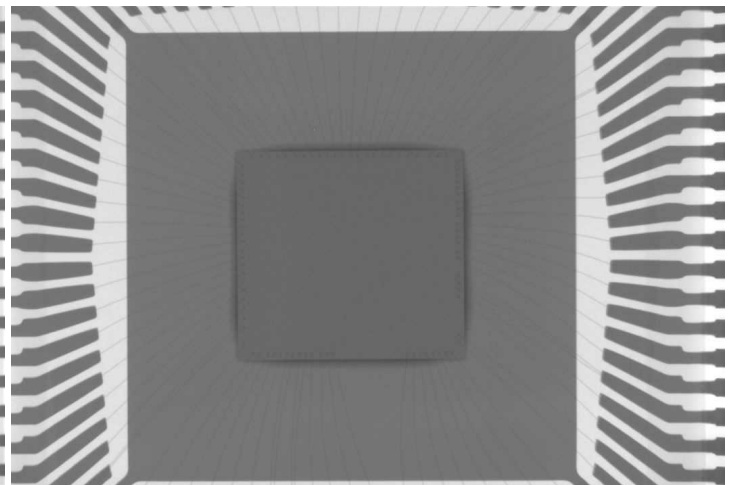

X-Ray Analysis - Die Shot Sample 3



## X-Ray Inspection ( Continued )

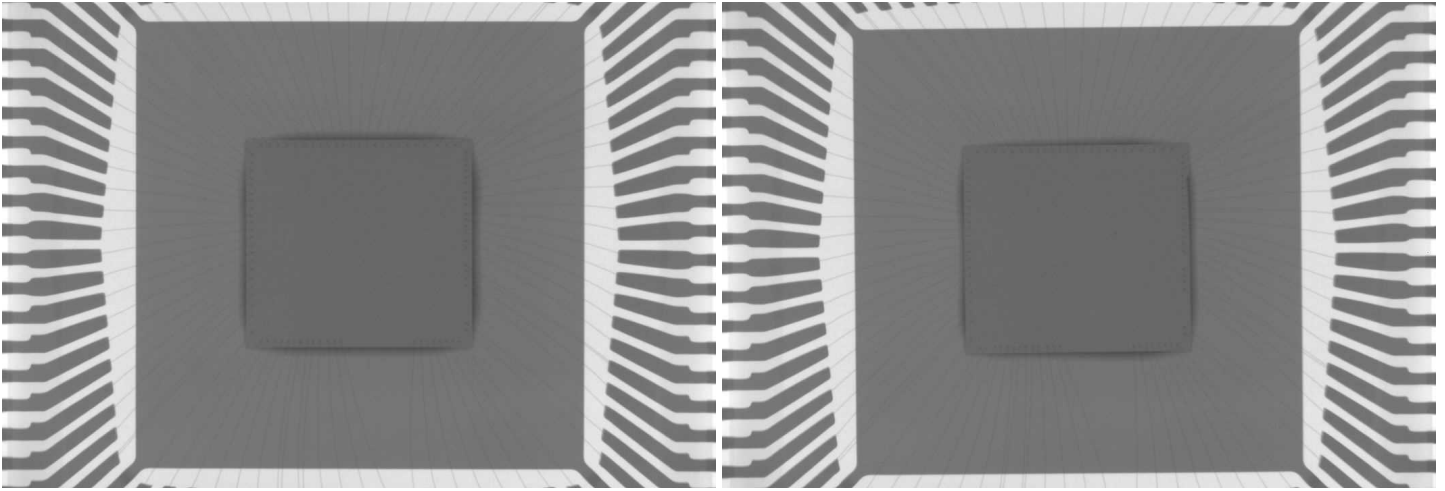

X-Ray Analysis - Die Shot Sample 4

X-Ray Analysis - Die Shot Sample 5



## Electrical Testing

Electrical Testing per AAA 622-001 Section 13

Test Type	Quantity Tested	Pass	Fail	Requirements
Memory Test	116 pcs.	116 pcs.	0 pcs. ( 0.00% )	Memory Test
Test Procedure	Devices were tested for the following using Segger J-Link Plus Tester at 25°C: - Insertion Test: Checks the pin contact before programming. - Read: The entire flash chip is read from the device.  Testing performed in accordance with AAA Test Procedure Manual, 622-001, Section 13			
Parameters Verified	Insertion, Memory (Read)			
Observation	116 devices passed all tested parameters.			
Equipment	Segger J-Link Plus Cable [E0025] Keithley 2230G-30-1 - Cal Due Date (1/15/24)			
Test Operator	J Burns			
Test Date	2/20/2023			

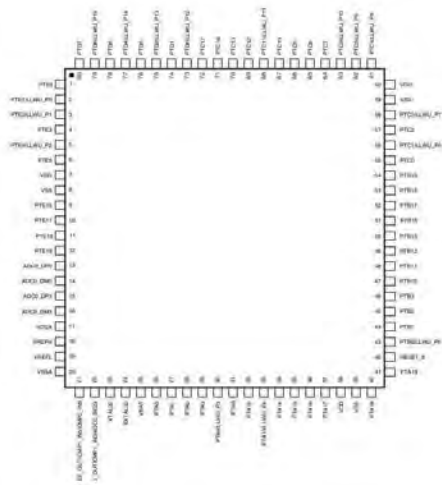

Device Package

```

Log
-----
Connecting ...
- Connecting via USB to probe/ programmer device B
- Probe/ Programmer firmware: J-Link V11 compiled Dec 14 2022 09:09:01
- Device "HW120X256XXX5 (ALLOW SECURITY)" selected.
- Target interface speed: 4000 kHz (Fixed)
- VTarget = 2.199V
- InitTarget()
- TotalIRLen = 4, IRPrint = 0x01
- JTAG chain detection found 1 devices:
- #0 ID: 0x4BA00477, IRLen: 04, CoreSight JTAG-DP
- Cannot determine DP version. Assuming DPv0
- Scanning AP map to find all available APs
- AP[2]: Stopped AP scan as end of AP map has been reached
- AP[0]: AHB-AP (IDR: 0x24770011)
- AP[1]: JTAG-AP (IDR: 0x001C0000)
- Iterating through AP map to find AHB-AP to use
- AP[0]: Core found
- AP[0]: AHB-AP ROM base: 0xE00FF000
- CPUID register: 0x410FC241. Implementer code: 0x41 (ARM)
- Found cortex-M4 r0p1, little endian.
- FPUnit: 0 code (SP) slots and 2 literal slots
- CoreSight components:
- ROMTbl[0] @ E00FF000
- ROMTbl[0][0]: E00E0000, CID: B105E000, PID: 00000000 SCS
- ROMTbl[0][1]: E0001000, CID: B105E000, PID: 003B0002 DWT
- ROMTbl[0][2]: E0002000, CID: B105E000, PID: 002E0003 FPF
- ROMTbl[0][3]: E0000000, CID: B105E000, PID: 003B0001 ITM
- ROMTbl[0][4]: E0040000, CID: B1059000, PID: 00009011 TPIU
- ROMTbl[0][5]: E0041000, CID: B1059000, PID: 00009025 ETM
- Executing init sequence ...
- Initialized successfully
- Target interface speed: 4000 kHz (Fixed)
- Found 1 JTAG device. Core ID: 0x4BA00477 (None)
- Connected successfully
  
```

Sample Device Passing JTAG Configuration (Insertion)





# Electrical Testing ( Continued )



Sample Device Passing Memory Read

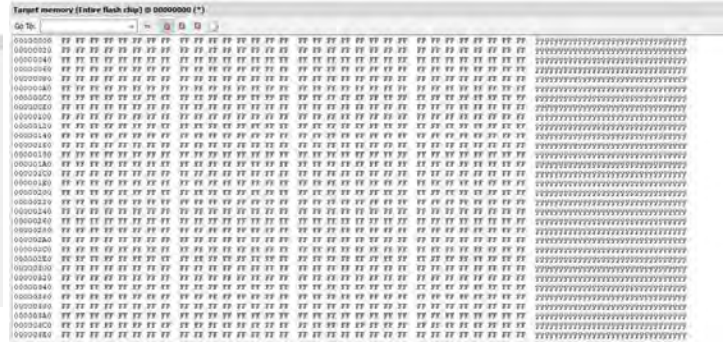

Sample Device Memory Contents



## Baking

General Conditions: Per JEDEC J-STD-033

Quantity	122	Baking start time	February 21, 2023 10:15 AM
MSL	Level 3	Baking end time	February 22, 2023 01:15 PM
Baking Temperature (°C)	125	Actual baking time	27 hours
Bag seal date	February 22, 2023		



## Shipping

Carrier	unknown	Service	

## Revision History

Revision #0 Date: 2/21/2023

---

Approved by :   
 \_\_\_\_\_  
 Gary Heyes  
 General Manager

AAA Test Lab is dedicated to ensuring the highest standard of product testing in the industry; it is not always possible within the scope of any given test to completely and exhaustively validate every variation of capabilities and / or functionality of any particular product tested and / or guarantees that any particular product tested is fit for any given purpose. All test results represent a snapshot of capability and not a guarantee of future product effectiveness. AAA Test Lab provides test results for any particular product tested and within the specified scope of testing and relative to the specific data sheet during the specific test process. The test results provided apply to the sample as received. AAA Test Lab is unable to directly endorse or certify the overall reliability of any particular product tested for any given situation or deployment. In no event shall AAA Test Lab Inc. be liable to any special, indirect or consequential damages or any damages whatsoever resulting from loss of any kind including profits, in any action arising out of or in connection with the test report or data associated with the report. This report shall not be reproduced, except in full without the approval of AAA.